

ART 231

Digital Art for Non-Art Majors / Soojin Kim

3D MODELING

3D SPACE

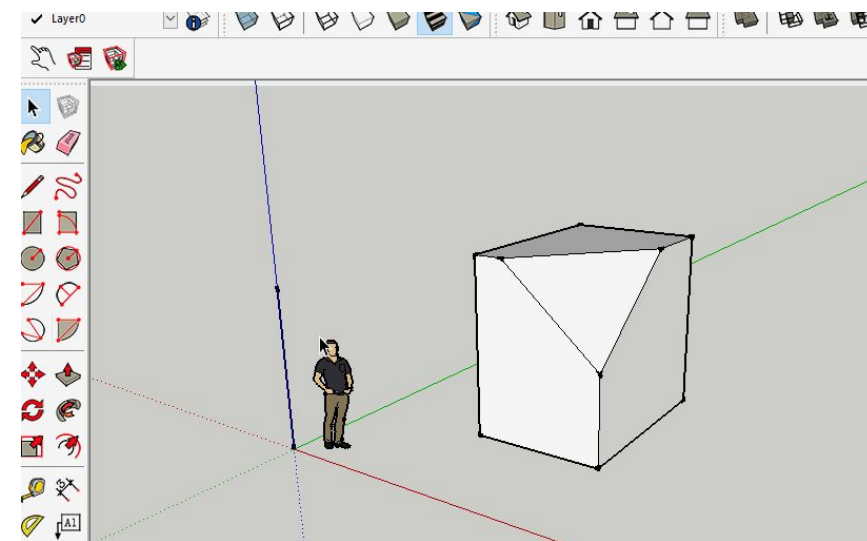
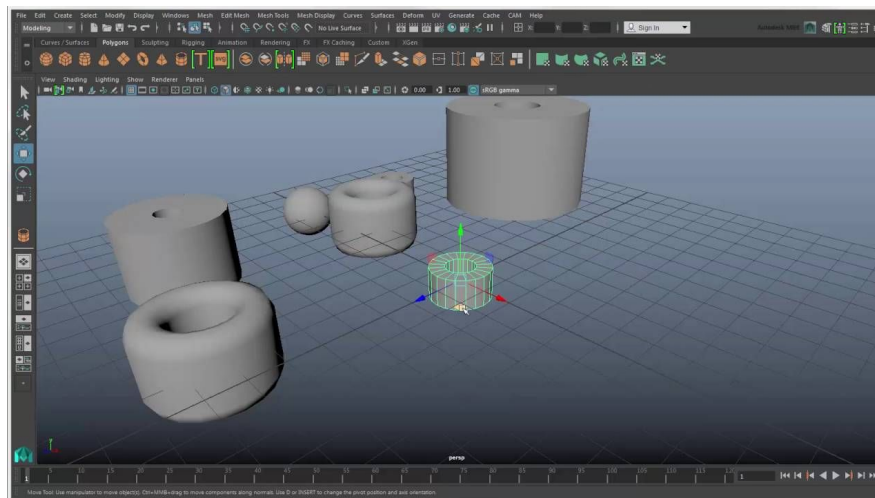
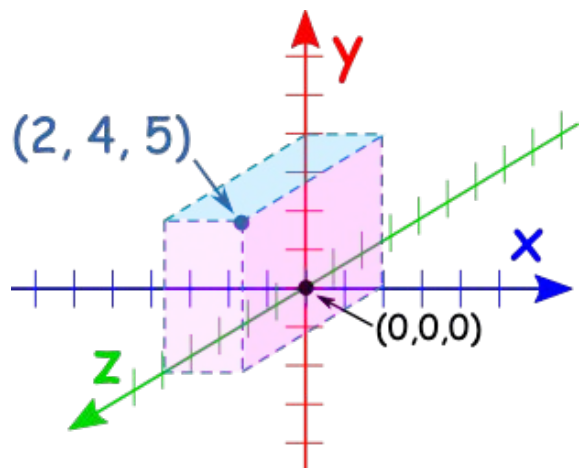

3D SHAPE MANIPULATION | EXTRUDE

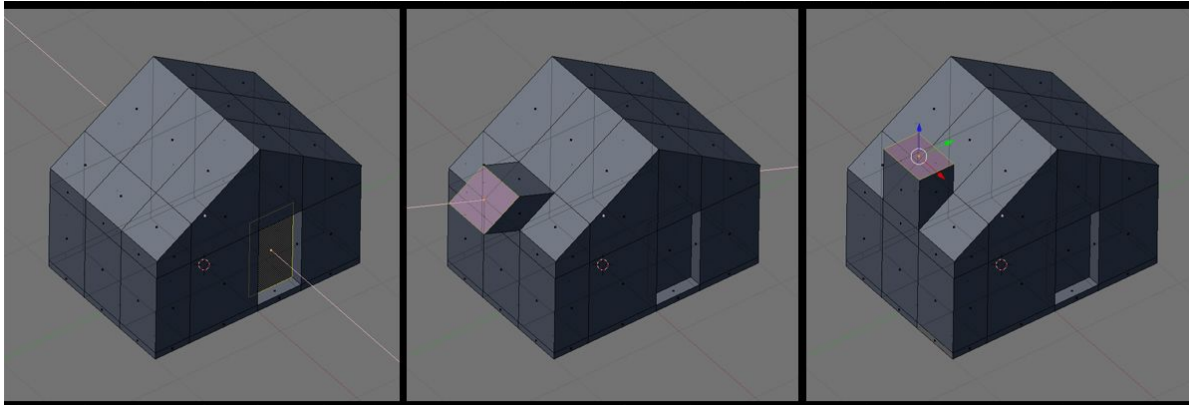
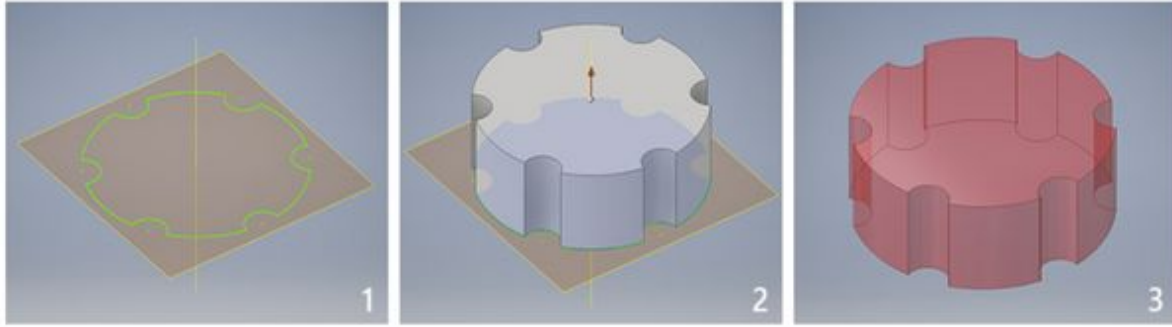

3D SHAPE MANIPULATION | EXTRUDE

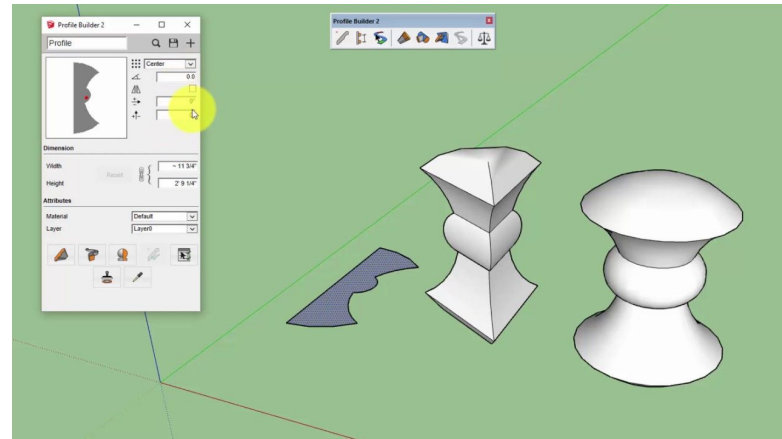
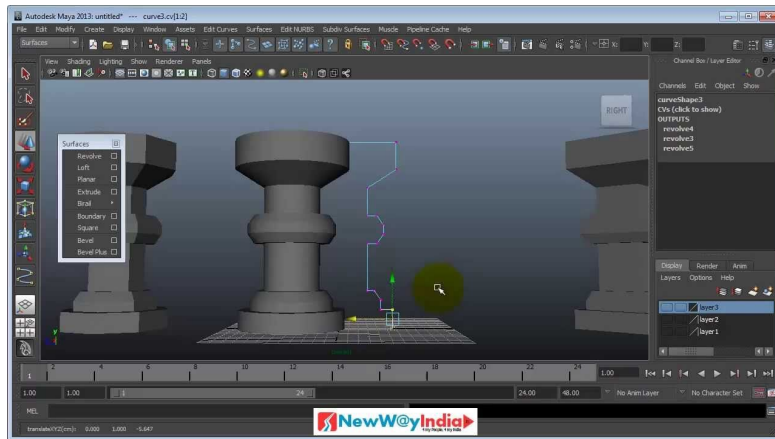
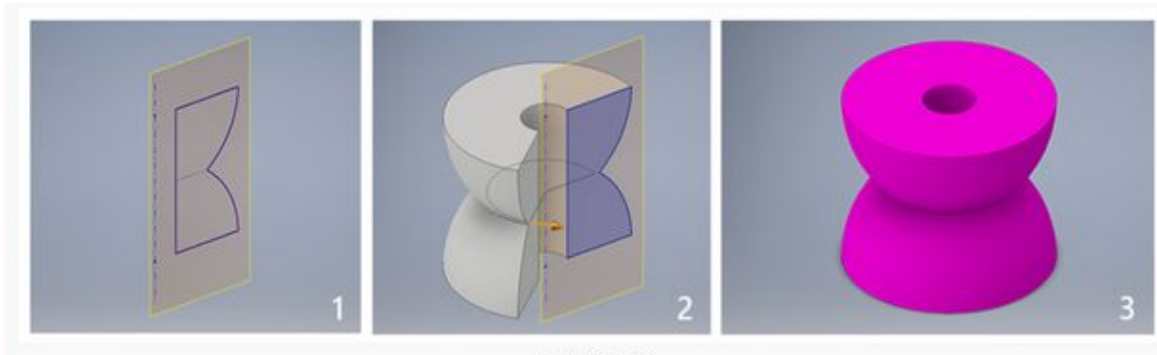

3D SHAPE MANIPULATION | LOFT

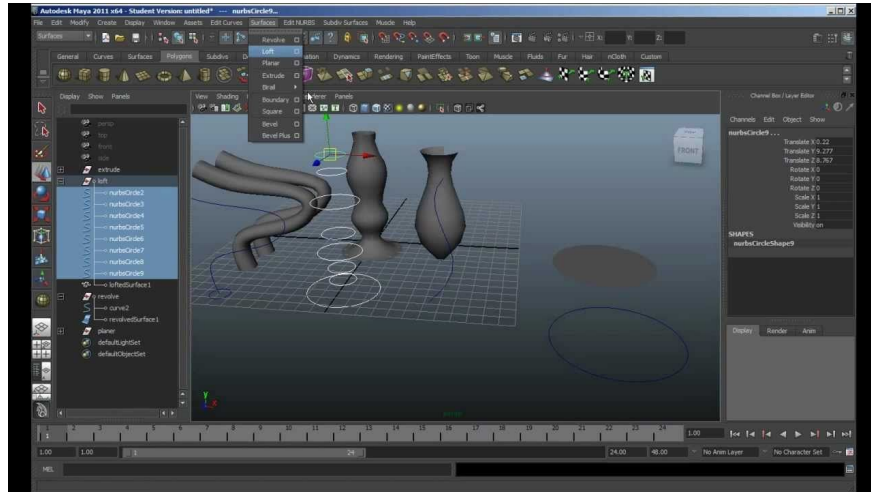
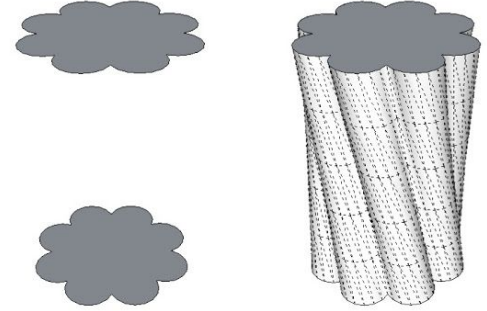

3D SHAPE MANIPULATION | Boolean Operation

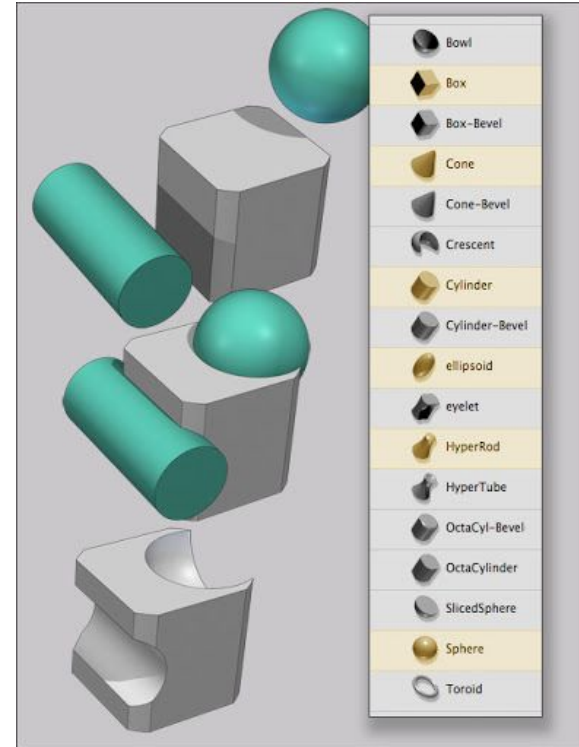
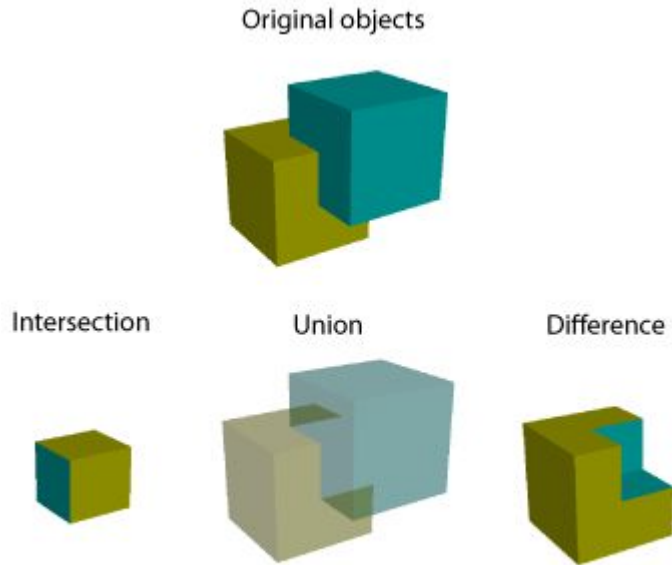

3D SHAPE BASICS | MAYA



3D CHESS PIECE EXAMPLE | MAYA

